



**CHANGING  
EXPECTATIONS**

## SHIFTER SYSTEMS

Kongsberg Automotive is one of the world's leading manufacturers of manual and electronic gear shifters, with our systems fitted to over four million vehicles each year across Europe, North America and Asia. Kongsberg Automotive has been designing and developing transmission shift controls for commercial vehicles for more than 40 years. Today we supply products to the world's leading manufacturers of trucks, buses and off-highway vehicles.

The new ES3000 is an innovative, high specification electronic shifter offering best-in-class performance and functionality, utilizing our revolutionary non-contact sensor.

The patented design of the vSENSE™ non-contact, programmable Hall effect sensor seals out contaminants to provide enhanced reliability in all environments. With no moving parts to wear over time, the vSENSE™ sensor sets a new standard for accuracy and durability, exceeding IP67 seal rating by performing under dynamic rather than static conditions.



## AT A GLANCE

- Innovative high specification electronic shifter, designed for robust, durable and consistent performance in even the most hostile working environments.
- Exchangeable detent plates provide variable shift angles and gates to suit customer requirements, with option to incorporate side movement of lever to follow Z-gate shift pattern.
- Optional illumination
- Easily installed into vehicle cabin
- vSense™ Hall effect non-contact sensor provides position sensing and switching accuracy and reliability
  - Fully programmable
  - Fully tested
  - (functionality, performance and EMC)
  - Fully sealed (IP67 dynamic)

# ES3000 SERIES ELECTRONIC SHIFTER

## ES3000 ELECTRONIC SHIFTER FEATURES, SPECIFICATION AND LAYOUT:

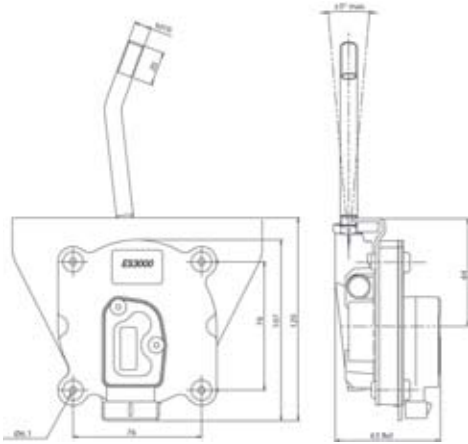

### PARAMETER

### SPECIFICATION

#### MECHANICAL SPECIFICATION

Temperature Operating Range	-40°C to +85°C
Functional Life (full rotation)	>1M Cycles tested
Load rating (mis-use)	1000N in any direction
Adjustment of Detent Force	Max 8Nm on lever between gates
Range of movement	
In Shift Direction	Maximum ±45°
In Side Direction	Maximum +10°
Seal compliant	IP67 Dynamic

### vSENSE™ NON-CONTACT SENSOR

### PARAMETER

### SPECIFICATION

Temperature Operating Range	-40°C to +85°C
Functional Life (full rotation)	>30M Cycles tested
Supply Current Draw	Max. 10mA per Output
Max continuous voltage on switch	+40v
Max continuous operating switch current	20mA
Output Range (programmable) within:	
Minimum	>7% of supply voltage
Maximum	<90% of supply voltage

#### Electrical Specification for Ratiometric Voltage Output

Supply (Reference Voltage)	5V ±0.5V
----------------------------	----------

#### Environmental Specification

EMC	150V/m
ESD	±15kV
Seal Compliant	IP67 Dynamic
Chemical Resistance per.	SAE J1455

#### Configuration

Programmable for dual/single analogue or PWM
Programmable for single track with switch

### OPTIONS:

- Shift lever movement:
  - Detent plate, standard or customized, with up to 14 positions
  - Reverse spring to return lever to Neutral-position
  - Friction pad
- Side movement of lever possible to follow a Z-gate shift pattern
- Options available for positional illumination
- Option available for additional switch
- Installation options:
  - Standard mounting bracket
  - No bracket
  - Customized bracket

### APPLICATIONS:

- Electronic shifter for automatic gear boxes
- Electronic hand control for construction vehicle implements
- Electronic throttle control, in master/slave combination with Teleflex throttle pedal.

### SENSOR FEATURES:

- High reliability and repeatability
- Excellent robustness and durability
- Integrated MetriPak connector or flying lead or flying lead + connector
- Total compensation of system tolerances
- No dynamic noise